

INSTALLATION INSTRUCTION

Colorscaping Transformer

8150CS-TRN-SS / 8300CS-TRN-SS



IMPORTANT:

Read all instructions before installing.

- Read all instructions before proceeding with the installation.
- This power supply complies with the requirements of UL1838. This power supply should be installed in compliance with the National Electrical Code and local electrical codes. This unit is for use with landscape lighting systems only.
- **WARNING –Risk of Electric Shock.** Install power unit 5 feet (1.5 m) or more from a pool or spa and 10 feet (3.05 m) or more from a fountain. Where the power unit is installed within 10 feet (3.05 m) of a pool or spa connect power unit to a GFCI protected branch circuit.
- Do not modify or change the product in any way. This product is to be installed by a qualified electrician only. Failure to do so will void the warranty and may result in serious injury and/or damage to the transformer.
- Connect directly to an outlet; do not use an extension cord with this product. For 120 Volt AC operation only. Be sure that the supply circuit is energized. If this occurs, the circuit breaker can be replaced with a breaker rated for high in-rush currents and should only be done by a qualified electrician.
- To avoid risk of fire do not use a fixture or a combinations of fixtures where the total watts exceed the rating of the power supply.

IMPORTANTE:

Lea todas las instrucciones antes de instalar.

- No conecte este temporizador en un cable de extensión u otro adaptador de corriente. Conecte directamente a una toma eléctrica.
- No conecte el contador a los aparatos que contienen elementos de calefacción (de aparatos de cocina, calentadores, planchas, etc.)
- El fallo del temporizador para apagar dicho dispositivo puede provocar un sobrecalentamiento y un posible incendio.
- No conecte este temporizador si está húmedo.
- No limpie este temporizador cuando está enchufado int.
- No exceder los valores máximos del temporizador.
- Posible riesgo de descarga: Mantener fuera del alcance de los niños.

IMPORTANT:

Lisez toutes les instructions avant de l'installer.

- Ne branchez pas ce temporisateur dans une rallonge ou un autre adaptateur électrique. Brancher directement dans une prise électrique.
- Ne pas relier cette minuterie pour les appareils qui contiennent éléments de chauffage (appareils de cuisson, chauffe, un fer à repasser, etc.)
- L'échec de l'horloge pour éteindre tel dispositif peut entraîner une surchauffe et un incendie.
- Ne branchez pas cette minuterie si elle est mouillée.
- Ne nettoyez pas ce temporisateur quand il est branché int.
- Ne pas dépasser les évaluations maximales de la minuterie.
- Risque d'électrocution: Conserver hors de la portée des enfants.

INSTALLATION GUIDELINES

- One or more circuit breakers are included with each transformer. To reset, turn breaker to on position. If circuit breakers trip repeatedly, have the system inspected by a qualified electrician.
- The transformer includes an internal thermal protector and will run the transformer off if the unit over-heats. The thermal protector will also automatically reset.
- Where possible, it is best to install the transformer in the center of the lighting installation to minimize long runs reducing voltage drop.

THIS INSTRUCTIONS APPLY TO THE MODEL BELOW:

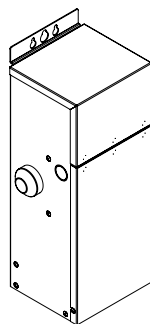

8150CS-TRN-SS

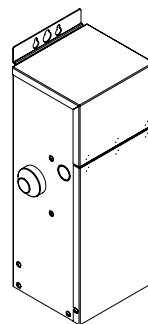

8300CS-TRN-SS

wacighting.com

Phone (800) 526.2588

Fax (800) 526.2585

Headquarters, East Manufacturing Facility

44 Harbor Park Drive

Port Washington, NY 11050

South East Manufacturing Facility

1600 Distribution Ct

Lithia Springs, GA 30122

Central Manufacturing Facility

1700 South J Elmer Freeway, Ste 100

Cedar Hill, TX 75104

West Manufacturing Facility

1750 S Archibald Ave

Ontario, CA 91761

INSTALLATION INSTRUCTION

Colorscaping Transformer

8150CS-TRN-SS / 8300CS-TRN-SS



CONTROL ZONES

Your Colorscaping transformer supports two separate control zones

Zone 1 – Smart Control or Legacy Control

Zone 2 – Legacy Control Only

Smart Control – Individually addressable full color and tunable white fixtures. Fixtures can be grouped and added to automations using the MyWAC App.

Legacy Control – Designed for use with traditional landscape fixtures. Zone can be turned on/off and dimmed as one circuit. Control available remotely via the MyWAC App

The MyWAC app will automatically recognize if a zone is in Legacy or Smart mode and will adjust accordingly.

WIRING

Do not use timers to control power to the transformer. For the system to work properly, the transformer needs to receive continuous power.

Local Control Panel

Your Colorscaping transformer features a transformer that can be used to operate the basic capabilities of the transformer with both Smart and Legacy zones.

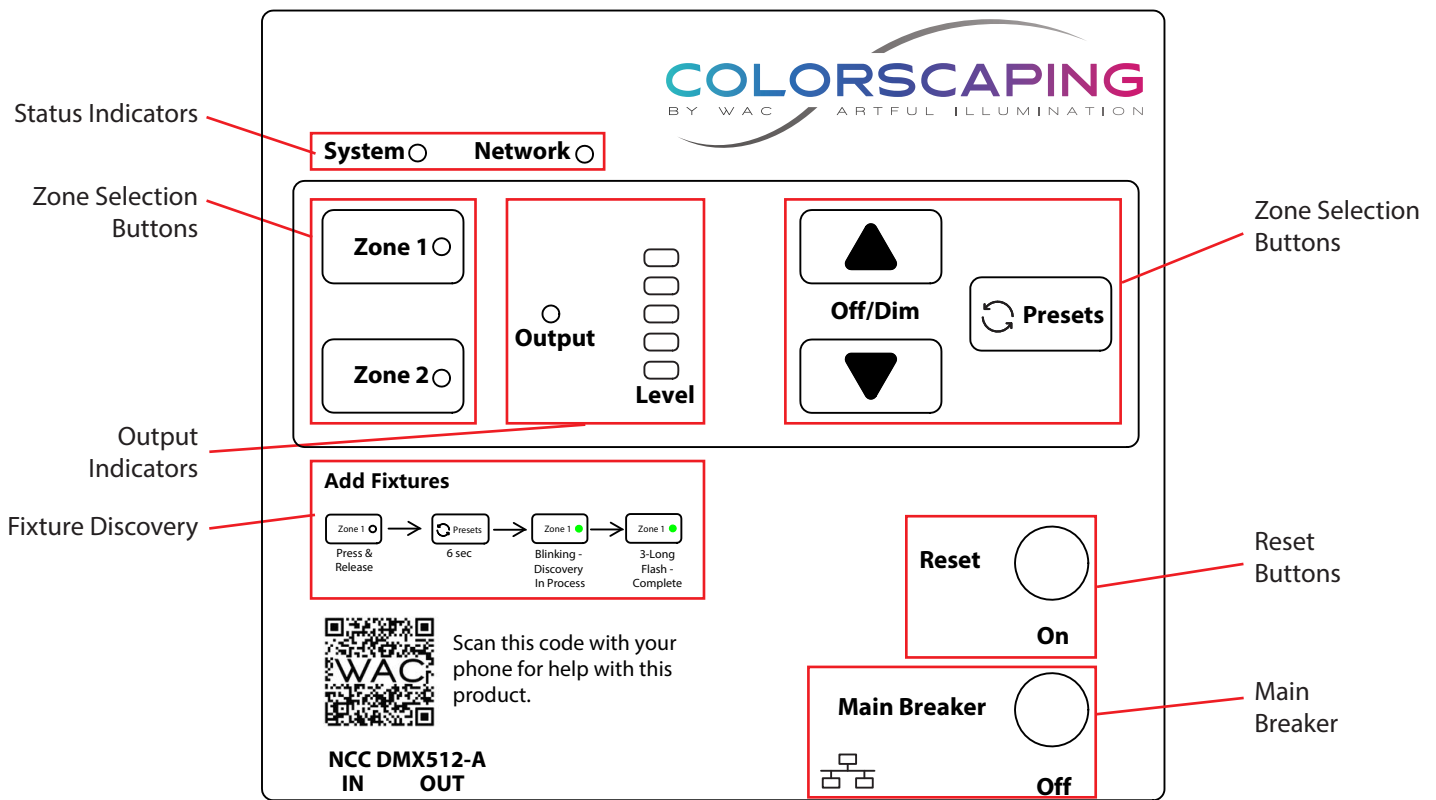

wacighting.com
Phone (800) 526.2588
Fax (800) 526.2585

Headquarters, East Manufacturing Facility
44 Harbor Park Drive
Port Washington, NY 11050

South East Manufacturing Facility
1600 Distribution Ct
Lithia Springs, GA 30122

Central Manufacturing Facility
1700 South J Elmer Freeway, Ste 100
Cedar Hill, TX 75104

West Manufacturing Facility
1750 S Archibald Ave
Ontario, CA 91761

INSTALLATION INSTRUCTION

Colorscaping Transformer

8150CS-TRN-SS / 8300CS-TRN-SS



Main Breaker

The main breaker will cut power to both the transformer electronics and the fixtures.

Zone Selection

A short tap on the button will activate the selected zone for control. The LED to the right of the zone name will illuminate to indicate that the zone has been selected.

For Zone 1, to change the zone from Smart Mode to Legacy Mode, press and hold the "Zone 1" button for 6 seconds. The color of the indicator LED will change indicating that you've changed modes as shown below

Smart Mode – Green LED

Legacy Mode – Red LED

Zone Control

Once a zone has been selected, you can use the Zone Control Buttons to adjust all fixtures on that zone. For Smart Mode zones, all fixtures in connected to the zone will change. For more granular control, use the MyWAC App.

The color being output on the fixtures will be shown on the output indicators.

Fixture Discovery

When fixtures are added or removed from a transformer: Press and Release the 'Zone 1' button. Depress the "Presets" button for 6 seconds until system beeps and 'Zone 1' indicator begins blinking. When discovery is complete, the 'Zone 1' indicator will emit three long flashes and will turn off.

Note: Fixtures attached to the transformer may flash numerous times during the discovery process.

Reset Operations

Factory Reset – Press and hold the reset button for 10 seconds until system beeps 3 times. The System status indicator will flash 20 times indicating the system has been reset to its factory settings.

NOTE: All information for this transformer including fixture names, groups, schedules, automations, etc will be erased. This is an irreversible operation.

Network Reset – Press the reset button 5 times quickly. The Network Status Indicator will flash 5 times indicating that the network subsystem has been reset. The system will then be ready for connection to another network via the MyWAC App. If the transformer is connected to the network via Ethernet it will reconnect and re-establish its connection to the cloud. NOTE: This operation will not remove the transformer from your cloud account and is intended only for use in changing Wi-Fi networks.

DMX Integration

Your Colorscaping Smart Transformer supports integrations with control systems via DMX512A. The standard pinout specified in the DMX512A standard is supported. If this is the last/only node on a DMX bus, you must install a terminal resistor on the 'OUT' port of the transformer.

Use caution to not unintentionally connect a DMX wire to the Ethernet port or a powered Ethernet wire to a DMX port as damage can occur and is not covered under the limited warranty.

Connectivity

Your Colorscaping transformer can be connected to the Internet using the MyWAC App available from the App Store or Google Play. Follow the instructions in the app to connect the transformer to the network via either Wi-Fi (2.4GHz Only) or the onboard ethernet connection in the transformer.

wacighting.com	Headquarters, East Manufacturing Facility	South East Manufacturing Facility	Central Manufacturing Facility	West Manufacturing Facility
Phone (800) 526.2588	44 Harbor Park Drive	1600 Distribution Ct	1700 South J Elmer Freeway, Ste 100	1750 S Archibald Ave
Fax (800) 526.2585	Port Washington, NY 11050	Lithia Springs, GA 30122	Cedar Hill, TX 75104	Ontario, CA 91761

INSTALLATION INSTRUCTION

Colorscaping Transformer

8150CS-TRN-SS / 8300CS-TRN-SS



MOUNTING INSTRUCTIONS:

1. Carefully locate and install the power supply so that it is not in contact with insulation or combustible materials. Provide minimum of 12 inches of airspace around the power supply. Transformer must also be mounted a minimum of 12 inches above grade. (Fig. 1)
2. Securely mount the power supply using the mounting brackets on the power supply enclosure. Drill screw holes at the right locations (see dimensions in Fig. 1) and make sure use appropriate screws for the selected mounting surface.
3. Hang transformer case securely over the screws.
4. Plug in the power cord to a GFCI protected outlet with a cover that complies with the National Electrical Code for the location.
5. Use appropriate and approved wiring methods to connect the power supply and the lighting fixtures.
6. When using this power supply, the voltage will be reduced and the current will be significantly increased.
7. When complete, make sure that the input current does not exceed the rating of the transformer.

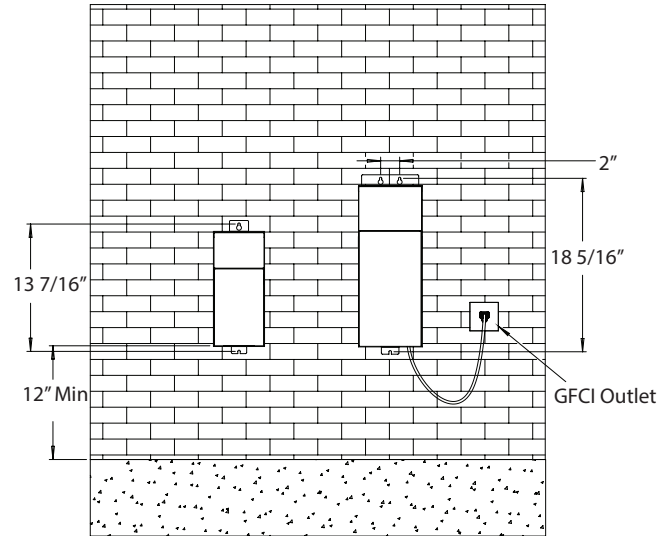

Fig. 1

TRANSFORMER SIZING - VA VALUE

Low voltage lighting systems require the use of a transformer to reduce the standard 120 volt power from ordinary household electricity to the 15 volt needed to power low voltage lamps. Transformers vary in size of capacity. The total lamp VA (load) of all fixtures connected to one transformer must not exceed the VA capacity of the transformer. Therefore, to determine the transformer size needed, simply add up the VA of all lamps you plan to use.

TRANSFORMER SIZE > TOTAL FIXTURE VA

Select a transformer that matches as closely as possible to your total lamp VA. If your total VA is too great, either divide the total load between two transformers or use a more powerful model. Selecting a transformer with about 20% higher capacity than your total lamp VA will allow for adding a fixture or two later.

wacighting.com

Phone (800) 526.2588

Fax (800) 526.2585

Headquarters, East Manufacturing Facility

44 Harbor Park Drive

Port Washington, NY 11050

South East Manufacturing Facility

1600 Distribution Ct

Lithia Springs, GA 30122

Central Manufacturing Facility

1700 South J Elmer Freeway, Ste 100

Cedar Hill, TX 75104

West Manufacturing Facility

1750 S Archibald Ave

Ontario, CA 91761

INSTALLATION INSTRUCTION

Colorscaping Transformer

8150CS-TRN-SS / 8300CS-TRN-SS



LOW VOLTAGE CABLE LENGTH

In planning a low voltage system, it is necessary to consider the impact of voltage drop. Because of cable's inherent resistance, voltage drops along its length: the end-of-run lamps will be dimmer than those at the beginning. Since voltage drop is a function of cable length and cable size and total fixture wattage, voltage drop can be minimized in several different ways:

- Use multiple cable runs
- Use heavier gauge cable(8 or 10 gauge)
- Shorten cable lengths or runs
- Reduce VA of individual fixtures
- Reduce the total number of fixtures on a run
- Use multiple transformers in different locations

Cable is measured by gauge. The lower the number, the thicker the cable and the more current it carries. Common cable size for low voltage lighting is available in three gauges: #12-2, #10-2, and #8-2. To calculate maximum cable length, use the formula below:

$$V_d = \frac{L \times VA \times 2}{K_c}$$

V_d = Voltage drop in the section of cable, in volts

L = Length of the section of the cable (one way distance), in feet

VA = Total VA values carried by the section of cable for the fixtures it

supplies K_c = Cable Constant as follow:

Cable Size	K_c
12	7500
10	11920
8	18960

Please refer to WAC Lighting website for voltage drop calculator

CABLE CONNECTION DETAIL

1. Open the cover of the transformer and remove the Knockouts at the bottom of the transformer as necessary.
2. Run lighting cables through Knockouts from the bottom of the transformer.
3. Connect the low voltage cables to the COMs and low voltage taps labeled on the Terminal Blocks. Open the Cable connecting levelers, insert the cables into the slot and close the levelers. Make sure that all Cable Connecting Screws are secure and tight.
4. Use Zone 1 for smart fixtures and Zone 2 for legacy fixture.

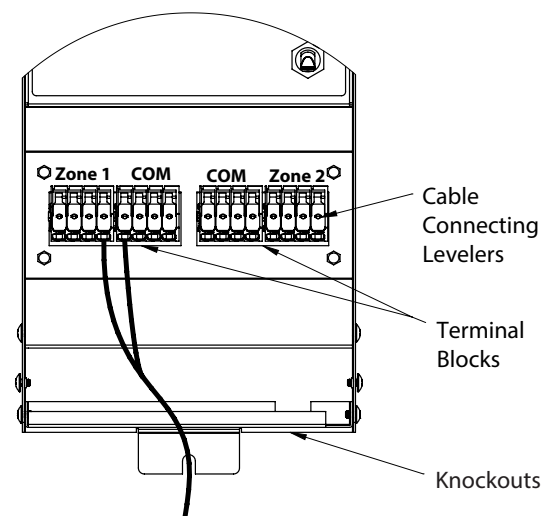

INSTALLATION INSTRUCTION

Colorscaping Transformer

8150CS-TRN-SS / 8300CS-TRN-SS



DMX CONNECTION DETAIL

1. Open the cover of the transformer and remove the Knockouts at the bottom of the transformer as necessary.
2. Run DMX and LAN cables through Knockouts from the bottom of the transformer.
3. Connect the DMX INPUT cable to the DMX IN and connect the DMX out with DMX512-A IN.
4. For LAN connection, run connect the LAN INPUT cable to LAN IN and connect LAN OUT to the top port as shown in the figure.
5. To connect to another smart transformer for DMX control, use the DMX OUT TO ANOTHER port as the DMX INPUT.

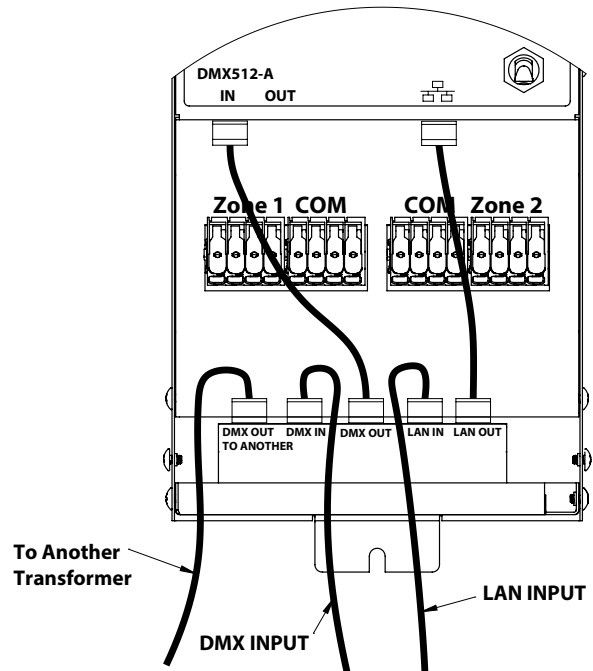

CHECK THE SYSTEM

After installing the entire low voltage system, operate the system for five minutes. On the low voltage side, all electrical connection spots should be cool to touch. If a connection is hot to the touch, retighten the connection and check to ensure that the temperature decreases.

Place the transformer cover back and tighten all four provided screws on both sides.

If there's any irregularities, email or call WAC Lighting "Technical Support" at Sales@wacighting.com, (800)526.2588.

wacighting.com

Phone (800) 526.2588

Fax (800) 526.2585

Headquarters, East Manufacturing Facility

44 Harbor Park Drive

Port Washington, NY 11050

South East Manufacturing Facility

1600 Distribution Ct

Lithia Springs, GA 30122

Central Manufacturing Facility

1700 South J Elmer Freeway, Ste 100

Cedar Hill, TX 75104

West Manufacturing Facility

1750 S Archibald Ave

Ontario, CA 91761